

EXHIBIT

"B"

OUT-OF-CITY WASTEWATER SERVICE AGREEMENT

THIS OUT-OF-CITY WASTEWATER SERVICE AGREEMENT ("Agreement"), is made and entered by and between ELMURR LLC, a Texas limited liability company, referred to herein as the "Customer," and the CITY OF ROUND ROCK, TEXAS a home-rule municipality located in Williamson and Travis Counties, State of Texas, referred to herein as the "City." The Customer and the City are hereinafter referred to collectively as "the Parties," or individually as a "Party."

RECITALS:

WHEREAS, the Customer is the owner of record of the property located at 101 Limmer Loop, Round Rock, Texas 78665 (the "Property"), being more particularly described in the attached Exhibit "A" which is hereby incorporated for all purposes; and

WHEREAS, the Property is not located within the corporate limits of the City; and

WHEREAS, the Customer wishes to develop an approximately 9,307 square foot retail center on the Property; and

WHEREAS, the Customer has requested wastewater collection and treatment services from the City; and

WHEREAS; the City has determined that it is desirable for Customer to receive wastewater service from the City notwithstanding the fact that the Property is outside the City's corporate limits, subject to the conditions set forth herein; and

WHEREAS, the Customer and the City desire to enter into this Agreement to formalize the terms by which the City will provide six (6) living unit equivalents of wastewater service to the Property, and

WHEREAS, pursuant to the Zoning and Development Code, Chapter 4, Article VI, Sec. 4-80, Code of Ordinances (2018 Edition), City of Round Rock, Texas, the City Council hereby determines that there is adequate capacity of wastewater treatment services available for the purpose of servicing Customer without impairing services within the City, NOW, THEREFORE:

WITNESSETH:

That for and in consideration of the mutual promises contained herein and other good and valuable consideration, and the covenants and agreements hereinafter contained to be kept and performed by the respective Parties hereto, it is agreed as follows:

Article I. Customer's Obligations Under this Agreement

1.01 Customer shall be required to own and install a standard wastewater service line which will connect with Siena Municipal Utility District's ("District") wastewater system as shown in Exhibit "B," incorporated herein by reference for all purposes. Customer shall be required to enter into a separate agreement with the District for pass-through wastewater service and maintain said agreement at all times during the term of this Agreement. Customer's wastewater flows shall enter the City's wastewater system as shown in Exhibit "B." Customer shall provide the City with a copy of the executed pass-through agreement with the District prior to the parties executing this Agreement, attached as Exhibit "C," incorporated herein by reference for all purposes.

1.02 Customer shall grant the City the right of entry and access to Customer's private wastewater line attached to the District's wastewater lines at all times to inspect, to investigate the source of operational or maintenance problems, to prevent or detect, minimize, or avert operational or maintenance problems, or for any other purpose reasonable related to the provision of service under this Agreement. The Customer will cooperate with the City to provide access for these purposes, provided that the City provides Customer at least one working day's written notice or, in the event of an emergency, prior notice by telephone, confirmed facsimile, or electronic mail of its need for access.

1.03 Customer shall be responsible for securing sufficient rights allowing Customer to construct, install, operate, maintain, inspect, reconstruct, enlarge, relocate, rebuild, repair, and remove a wastewater system and lines, together with all necessary lines, pipes, conduits, manholes, ventilators, and other equipment, improvements, accessories and appurtenances or operations thereto, in, upon, over, under, above and across any necessary areas of private or public property to connect to the District's wastewater system. Customer has provided City an agreement evidencing said connection rights, attached as Exhibit "C." Such right shall not conflict with any existing easements held by the City.

1.04 Customer shall comply with all requirements of the Zoning and Development Code, Chapter 4, Article VI, Sec. 4-80, Code of Ordinances (2018 Edition), City of Round Rock, Texas, regarding the furnishing of sewer services outside the city limits, a copy of such Sec. 4-80 being attached hereto as Exhibit "D," incorporated herein by reference. Failure to comply with any of these requirements shall give the City the option of terminating this Agreement.

1.05 Customer agrees that in the event the Property becomes contiguous with the City limits of Round Rock, Texas, and meets all requirements of annexation, the owner of the Property shall immediately apply for annexation into the City, and cooperate fully with the annexation of the Property into the City and any zoning requirements of the City.

1.06 Any wastewater line that will be owned by the City shall be permitted through the City's development office.

Article II. Provision of Wastewater Services

2.01 City agrees to sell Customer wastewater service as required by Customer for domestic use on an as needed basis for a retail center located on the Property.

2.02 The wastewater service to be provided herein is for the Property as described in Exhibit "A" and no other property.

Article III. Rates and Fees

3.01 Prior to connecting to the City's wastewater system, Customer agrees to pay City a one-time wastewater connection fee of \$10,794.00. Any additional service resulting from future additions built on the Property shall require Customer to pay additional impact fees in accordance with Zoning and Development Code, Chapter 4, Article VI, Sec. 4-82, Code of Ordinances (2018 Edition), City of Round Rock, Texas, and as may be amended from time to time.

3.02 Customer agrees to pay City for all wastewater services provided to Customer at the rate authorized by Chapter 44, Article II, Sec. 4-34, Code of Ordinances (2018 Edition), City of Round Rock, Texas, as amended from time to time, applicable to customers located outside the corporate limits of the City. Consistent with that provision, the volume charge shall be twice the rate for commercial customers located within the corporate limits of the City. Because the Property is served with water from Jonah Water Special Utility District (Jonah SUD), the wastewater service will be calculated based on the Customer's average water consumption for December, January, and February of each winter, as determined from Jonah SUD's water bills. Customer agrees to provide the City with copies of the aforesaid bills by April 1, of each year.

3.03 The City shall render monthly bills to Customer for wastewater services. Payment shall be made no later than the sixteenth (16th) day following the mailing of the bill. Failure by Customer to make a payment when and as specified will give the City the option to terminate all obligations of the City under this Agreement.

3.04 Customer shall be subject to the penalty provisions for late payment as now exist in Chapter 44, Code of Ordinances (2018 Edition), City of Round Rock, Texas, and as may be amended from time to time.

Article IV. Compliance with Ordinances

4.01 Customer agrees to comply with all of City's ordinances as they now exist or may be amended from time to time regarding the sanitary use of the wastewater treatment system.

4.02 Customer agrees to pay the one-time wastewater connection fee as set forth in Sec. 3.01 above and to pay all other fees applicable to wastewater service.

4.03 Customer agrees and understands that the City's willingness to provide wastewater service to the Property is expressly contingent on the Property continuing to be used for its proposed uses, namely a retail enter. Customer shall not change or expand the existing

uses without the express written consent of the City, which may be withheld for any reason. Any change or expansion of uses without the consent of the City will give the City the option of terminating this Agreement.

4.04 Customer agrees that it will comply with all of the City's ordinances regarding subdivision, zoning, development, and building permits.

Article V. Force Majeure

5.01 In the event either Party is rendered unable, wholly or in part, by force majeure to carry out any of its obligations under this Agreement, then the obligations of that Party, to the extent affected by the force majeure and to the extent that due diligence is being used to resume performance at the earliest practicable time, shall be suspended during the continuance of the inability. The cause, as far as possible, shall be remedied with all reasonable diligence. The term "force majeure" includes acts of God, strikes, lockouts or other industrial disturbances, acts of the public enemy, orders of the government of the United States or the State of Texas or any civil or military authority, insurrections, riots, epidemics, landslides, lightning, earthquakes, fires, hurricanes, storms, floods, washouts, droughts, arrests, restraints of government and people, civil disturbances, explosions, breakage or accidents to equipment, pipelines, or canals, partial or entire failure of water supply, and any other incapacities of either Party, whether similar to those enumerated or otherwise, that are not within the control of the Party claiming the inability and that could not have been avoided by the exercise of due diligence and care. It is understood and agreed that the settlement of strikes and lockouts shall be entirely within the discretion of the Party having the difficulty and that the requirement that any force majeure be acceding to the demands of the opposing party if the settlement is unfavorable to it in the judgment of the Party having the difficulty. Force majeure shall relieve City from liability to Customer for failure to provide water service due to an inability covered by this article. Force majeure shall not relieve Customer of its obligation to make payments to City as provided in this Agreement.

Article VI. Term

6.01 The term of this Agreement shall be for a term of twenty (20) years from the date hereof.

6.02 This Agreement shall become null and void upon the annexation of the Property by the City.

Article VII. Miscellaneous Provisions

7.01 Customer is prohibited from selling or giving wastewater service purchased herein to anyone else.

7.02 Customer shall be permitted to assign its right herein to a bona fide purchaser of the Property as long as the intended use of the service and the Property remains the same or similar.

7.03 This Agreement shall be construed under and in accordance with the laws of the State of Texas, and any and all actions brought to enforce the terms of this Agreement shall be brought in Williamson County, Texas.

7.04 This Agreement shall be binding upon and inure to the benefit of the Parties hereto and their respective heirs, executors, administrators, legal representatives, successors, and assigns where permitted by this Agreement.

7.05 In case any one or more of the provisions contained in this Agreement shall for any reason be held to be invalid, illegal, or unenforceable in any respect, such invalidity, illegality, or unenforceability shall not affect any other provision thereof, and this Agreement shall be construed as if such invalid, illegal, or unenforceable provision had never been contained herein.

7.06 This Agreement constitutes the sole and only agreement of the parties hereto and supersedes any prior understandings or written or oral agreements between the parties respecting the within subject matter.

7.07 The violation by Customer of any of City's ordinances related to the use or disposition of wastewater, or to subdivision, zoning, development or building ordinances shall render this Agreement voidable at the option of City.

IN WITNESS HEREOF, the parties have executed this Out of City Wastewater Service Agreement in two (2) counterparts, each of which will be deemed an original on this the _____ day of _____, 2023.

ELMURR LLC

By: _____
Name: Nabil Elmurr
Customer's Mailing Address:
3800 Hidden Estates Drive
Austin, Texas 78727

CITY OF ROUND ROCK, TEXAS

By: _____
Craig Morgan, Mayor

Attest:

Meagan Spinks, City Clerk

For City, Approved as to Form:

Stephanie Sandre, City Attorney

EXHIBIT "A"
LEGAL DESCRIPTION

Lot 3, Block "A", Siena Section 35, a subdivision in Williamson County, Texas, according to the map or plat thereof, recorded in Document No. 2020046670 of the Official Public Records of Williamson County, Texas.

EXHIBIT "B"
DISTRICT WASTEWATER POINT OF CONNECTION

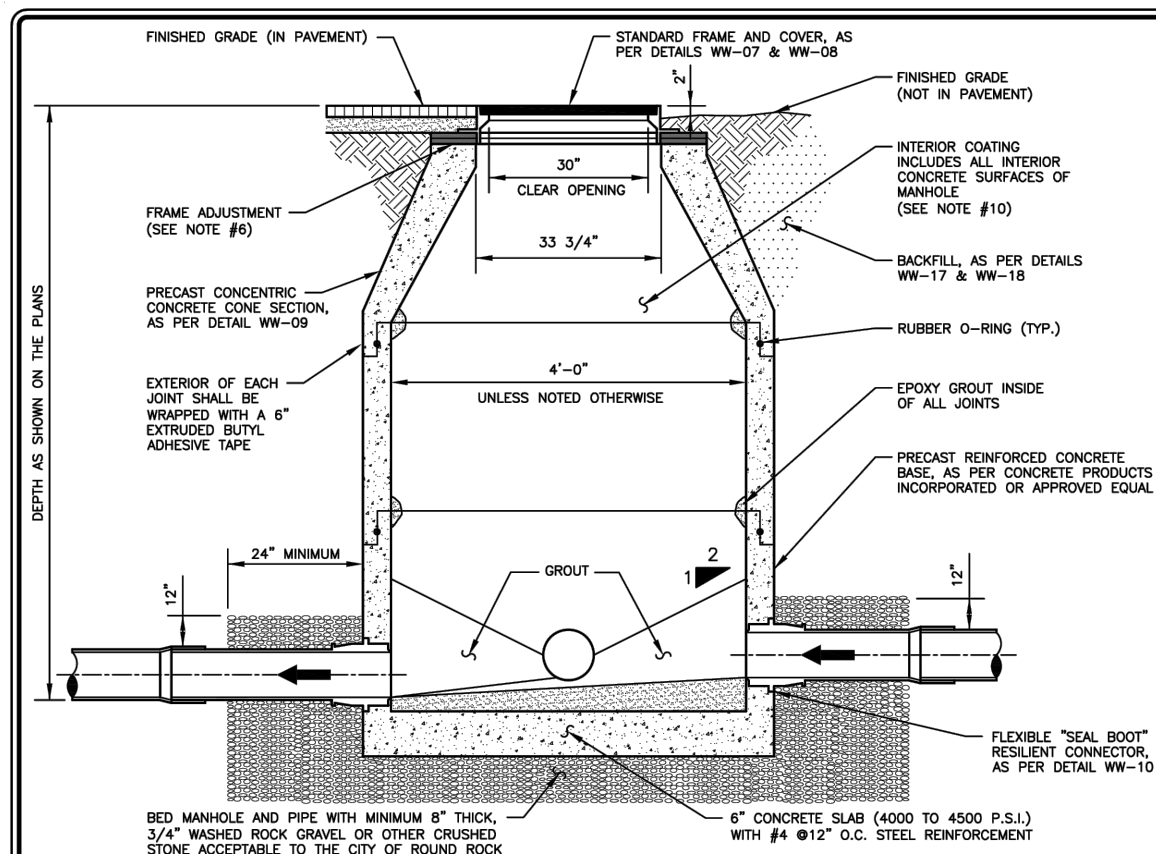

- NOTES:**
- IF DROP IS SIX INCHES (6") TO TWO FEET (2'-0"), CONSTRUCTION OF DROP SHALL PROVIDE AN INVERTED INVERT TO EXTEND UNDER THE DROP CONNECTION.
 - SEE CONSTRUCTION PLANS FOR MANHOLE SIZE, LOCATION, CONFIGURATION, TYPE OF TOP SECTION, VENTING REQUIREMENTS, PIPE SIZES AND TYPES.
 - MANHOLES SHALL BE PRECAST A.S.T.M. C478 BELL AND VERTICAL JOINTS WITH 70" RING JOINTS.
 - MANHOLES TO BE DESIGNED TO RESIST LATERAL AND VERTICAL SOIL PRESSURES RESULTING FROM MANHOLE DEPTH. ADDITIONALLY, MANHOLES LOCATED IN PAVEMENT TO BE DESIGNED FOR HIGH TRAFFIC LOADING.
 - ALL MANHOLE COVERS SHALL BE BOLTED AND DASKETED, WHEN MANHOLES ARE LOCATED OUTSIDE OF PAVEMENT.
 - FRAME ADJUSTMENT HEIGHT SHALL CONSIST OF FIVE INCHES (5") MINIMUM TO EIGHTEEN INCHES (18") MAXIMUM. GRADE RINGS SHALL BE GROUDED WITH A NON-SHRINK GROUT INSIDE AND OUTSIDE. HOPE GRADE RINGS MAY NOT BE USED.
 - FOR MANHOLES TO BE VENTED, SEE DETAILS WW-05 AND WW-06.
 - A FLOW CHANNEL SHALL BE CONSTRUCTED INSIDE MANHOLE TO DIRECT INFLUENT INTO THE FLOW STREAM. ALL P.V.C. PIPE SHALL BE REMOVED FROM INVERT.
 - BASE SECTION SHALL BE DESIGNED FOR HIGH TRAFFIC LOADING, PLUS EARTH LOAD AT 130 P.S.F.
 - ENTIRE INTERIOR CONCRETE SURFACES OF WASTEWATER MANHOLES TO BE COATED WITH RAVEN 405, SPRAYWALL, OR APPROVED EQUAL, WITH A UNIFORM THICKNESS OF 124 MILS AND A MINIMUM THICKNESS OF 100 MILS. APPLIED AFTER MANHOLE HAS PASSED THE VACUUM TEST. FOR REHABILITATING MANHOLES 1/2" MINIMUM THICKNESS CALCIUM ALUMINATE CEMENTITIOUS COATING AND OTHER INTERIOR SURFACES MAY BE COATED IF RECOMMENDED BY COATING MANUFACTURER. (ON LEV OF INTERIOR COATINGS NEW PRECAST MANHOLES CONTAINING CONSHIELD WILL BE ACCEPTED PROVIDED THE MANUFACTURER STENCILED "CONSHIELD" ON THE INSIDE AND OUTSIDE OF ALL MANHOLE SECTIONS.)

RECORD SIGNED COPY ON FILE AT URS DEPARTMENT APPROVED 03-01-18 DATE CITY OF ROUND ROCK DRAWING NO. WW-01 PRECAST CONCRETE WASTEWATER MANHOLE DETAIL

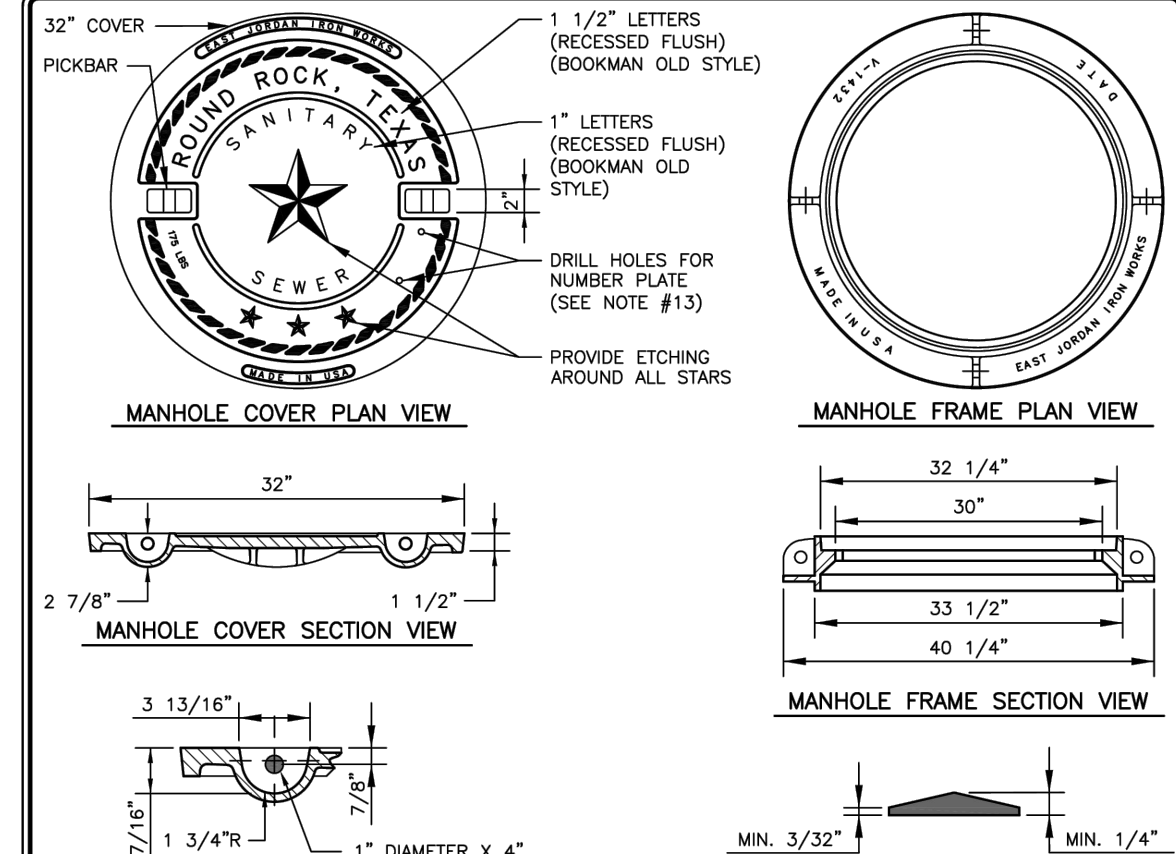

- NOTES:**
- COVER AND FRAME SHALL COMPLY WITH STANDARD SPECIFICATIONS FOR DRAINAGE, SEWER, UTILITY AND RELATED CASTINGS: AASHTO DESIGNATION M306-04.
 - MANHOLE COVER SHALL BE MODEL NUMBER: V-1432-3 (PRODUCT NUMBER: 41432099), AS MANUFACTURED BY EAST JORDAN IRON WORKS INCORPORATED, OR APPROVED EQUAL.
 - MANHOLE FRAME SHALL BE MODEL NUMBER: V-1432 (PRODUCT NUMBER: 41432010), AS MANUFACTURED BY EAST JORDAN IRON WORKS INCORPORATED, OR APPROVED EQUAL.
 - MANHOLE COVER AND FRAME ASSEMBLY, IF ORDERED AS A SET, SHALL BE MODEL NUMBER: V-1432 (PRODUCT NUMBER: 41432089), AS MANUFACTURED BY EAST JORDAN IRON WORKS INCORPORATED, OR APPROVED EQUAL.
 - ALL CORNERS AND EDGES SHALL HAVE A 1/16" MINIMUM AND 1/8" MAXIMUM RADIUS.
 - MANHOLE COVERS SHALL BE CAST WITH TWO 1" DIAMETER STEEL PICKBARS.
 - MANHOLE COVER WEIGHT SHALL BE 175 LBS. FOR DUCTILE IRON. WEIGHT SHALL BE CAST ON BOTH TOP AND BOTTOM OF COVER.
 - MANUFACTURER SHALL CERTIFY THAT EACH MANHOLE COVER MEETS HS-20 LOADING.
 - FILLETS SHALL BE 1/4" RADIUS UNLESS OTHERWISE SPECIFIED.
 - MANUFACTURER SHALL REMOVE EXCESS IRON AND MACHINE FINISH SEATING SURFACES TO NOTED DIMENSIONS.
 - COVER SHALL BE SUPPLIED IN A WATER-BASED ASPHALTIC COATING, PRIOR TO SHIPMENT FROM FOUNDRY.
 - MANUFACTURER SHALL DRILL 2-3/16" X 1/2" DEEP HOLES FOR A MANHOLE NUMBER PLATE TO BE PROVIDED BY THE CITY OF ROUND ROCK. THE TOP HOLE SHALL BE DRILLED 1" O.C. FROM THE BOTTOM OF THE PICKBAR AND THE BOTTOM HOLE SHALL BE DRILLED 4" O.C. FROM THE TOP HOLE.

RECORD SIGNED COPY ON FILE AT URS DEPARTMENT APPROVED 03-01-18 DATE CITY OF ROUND ROCK DRAWING NO. WW-08 NON-BOLTED WASTEWATER MANHOLE COVER AND FRAME DETAIL

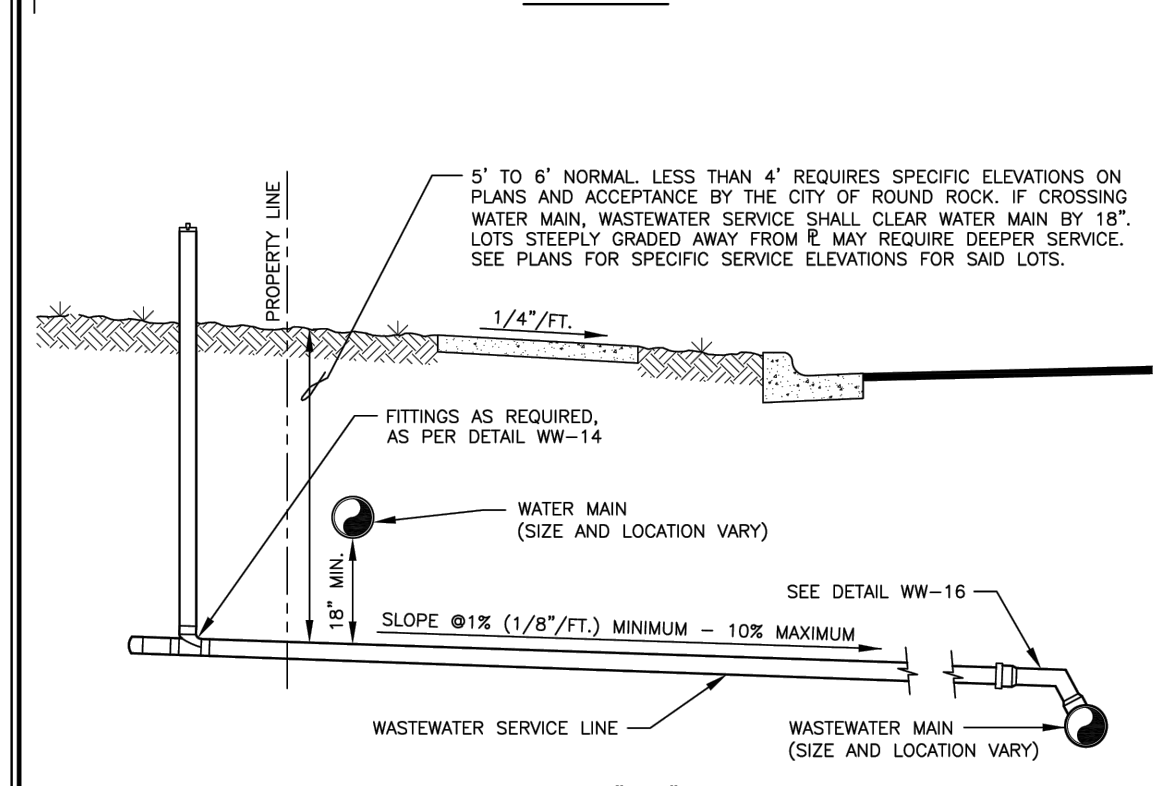
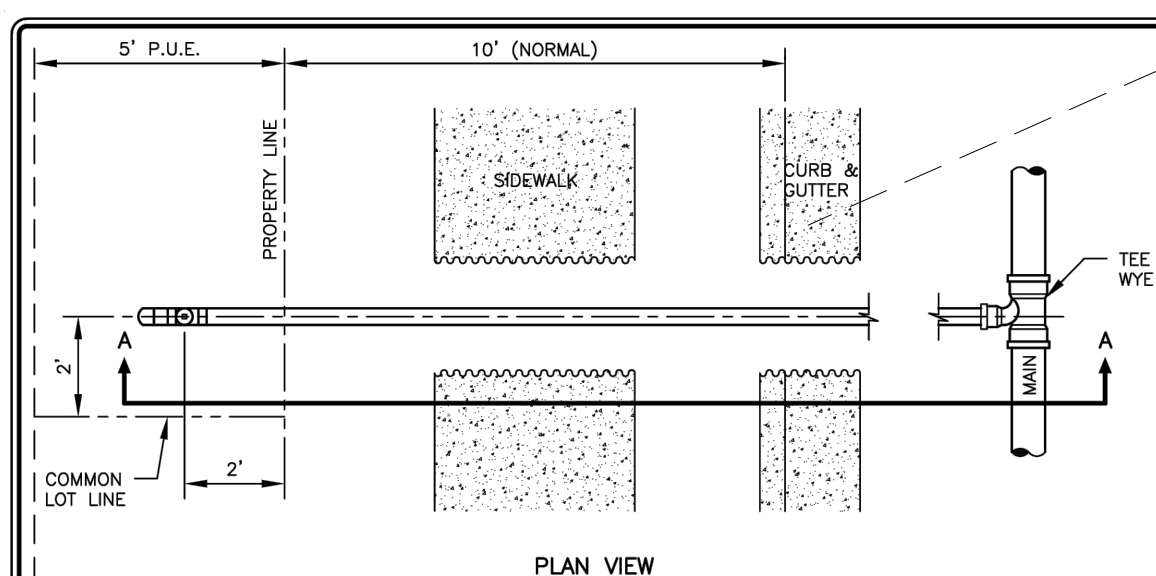

RECORD SIGNED COPY ON FILE AT URS DEPARTMENT APPROVED 03-01-18 DATE CITY OF ROUND ROCK DRAWING NO. WW-12 WASTEWATER SERVICE DETAIL

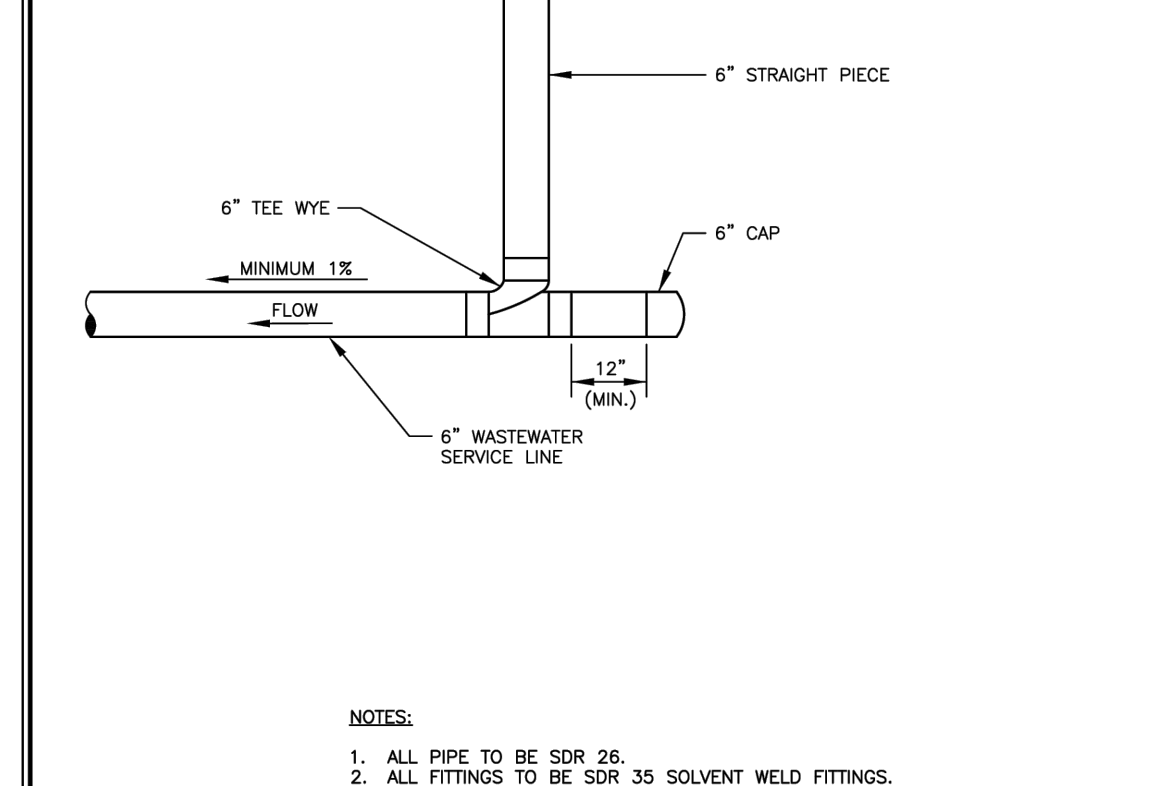
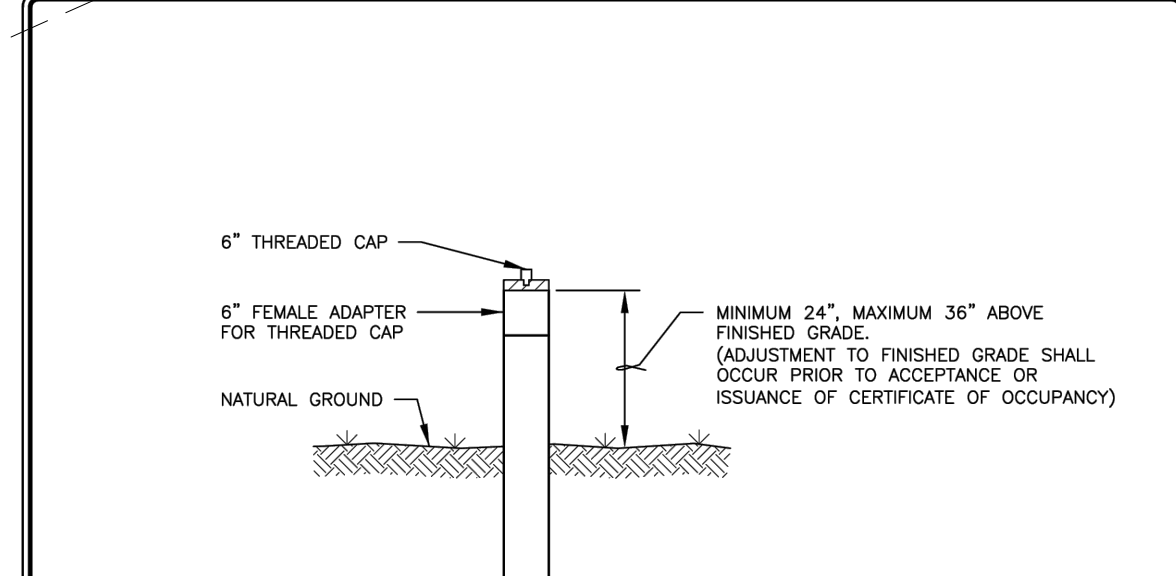

RECORD SIGNED COPY ON FILE AT URS DEPARTMENT APPROVED 03-01-18 DATE CITY OF ROUND ROCK DRAWING NO. WW-14 WASTEWATER SERVICE CLEAN-OUT DETAIL (NON-PAVED SURFACE)

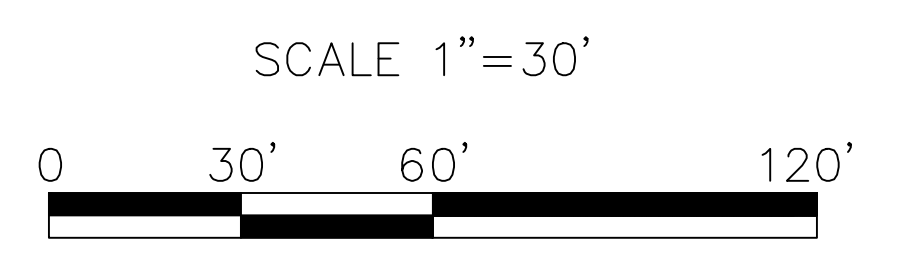
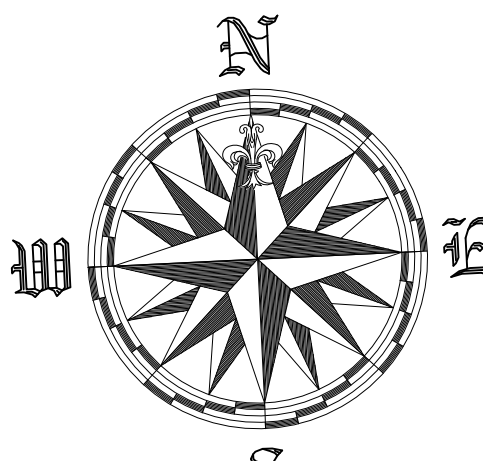
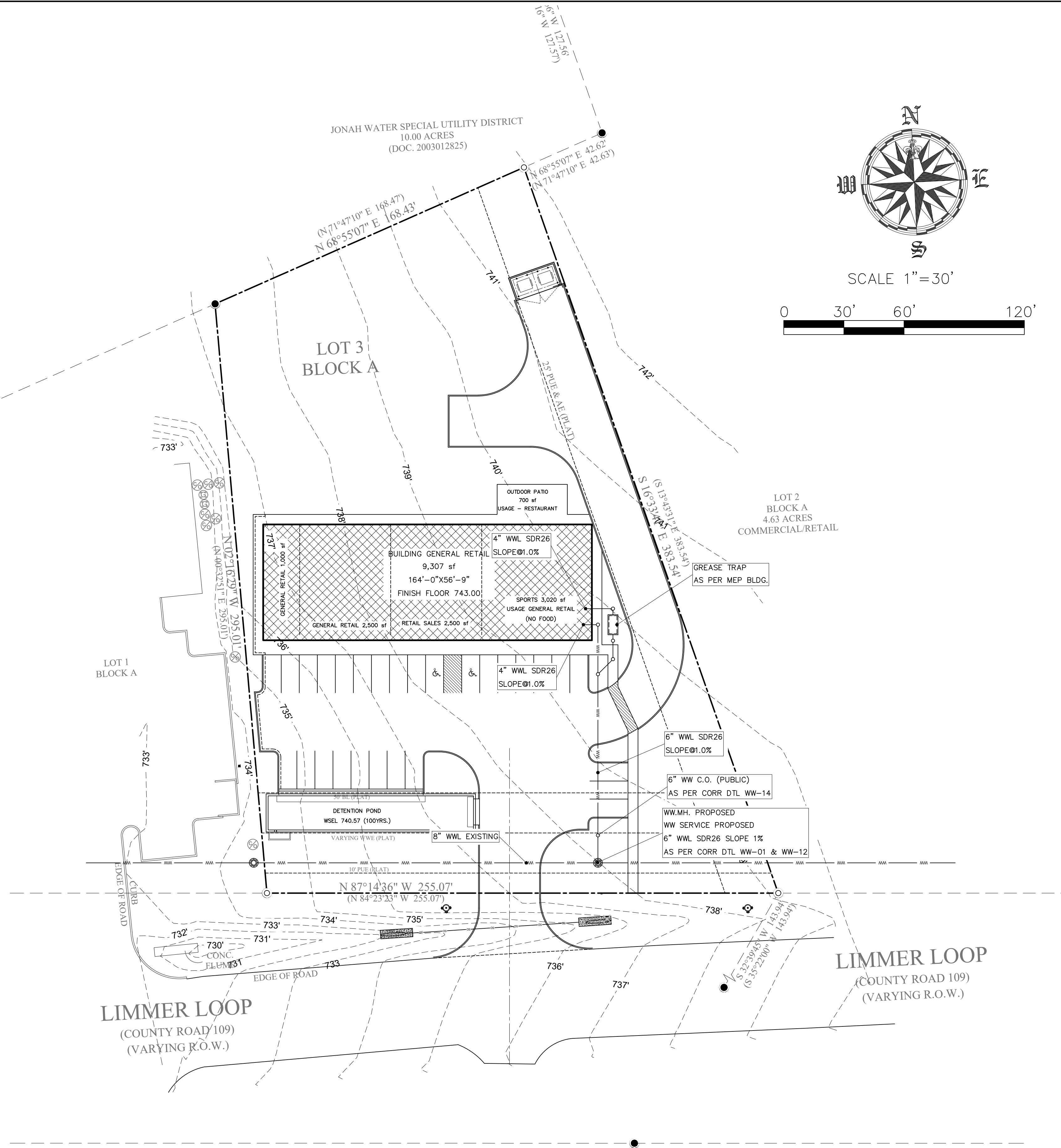

Professional Structural Engineers, Inc. Consulting Civil and Structural Engineers. 2205 WEST PARKER LANE, SUITE 210, AUSTIN, TX 78727 | TEL: 512.238.6422 | PEO@PSEINC.COM

Project: LIMMER RETAIL CENTER 101 LIMMER LOOP CITY OF HUITO, TEXAS 78634 Title: UTILITY SITE PLAN

30717 SHEET 8 OF 18

Exhibit "B"

LEGEND

- = 10' INLET
- ⊗ = WATER VALVE
- ⊗ = STORM SEWER MH
- ⊗ = WASTEWATER MH
- ⊗ = FIRE HYDRANT
- = IPF

SCALE: 1"=100'

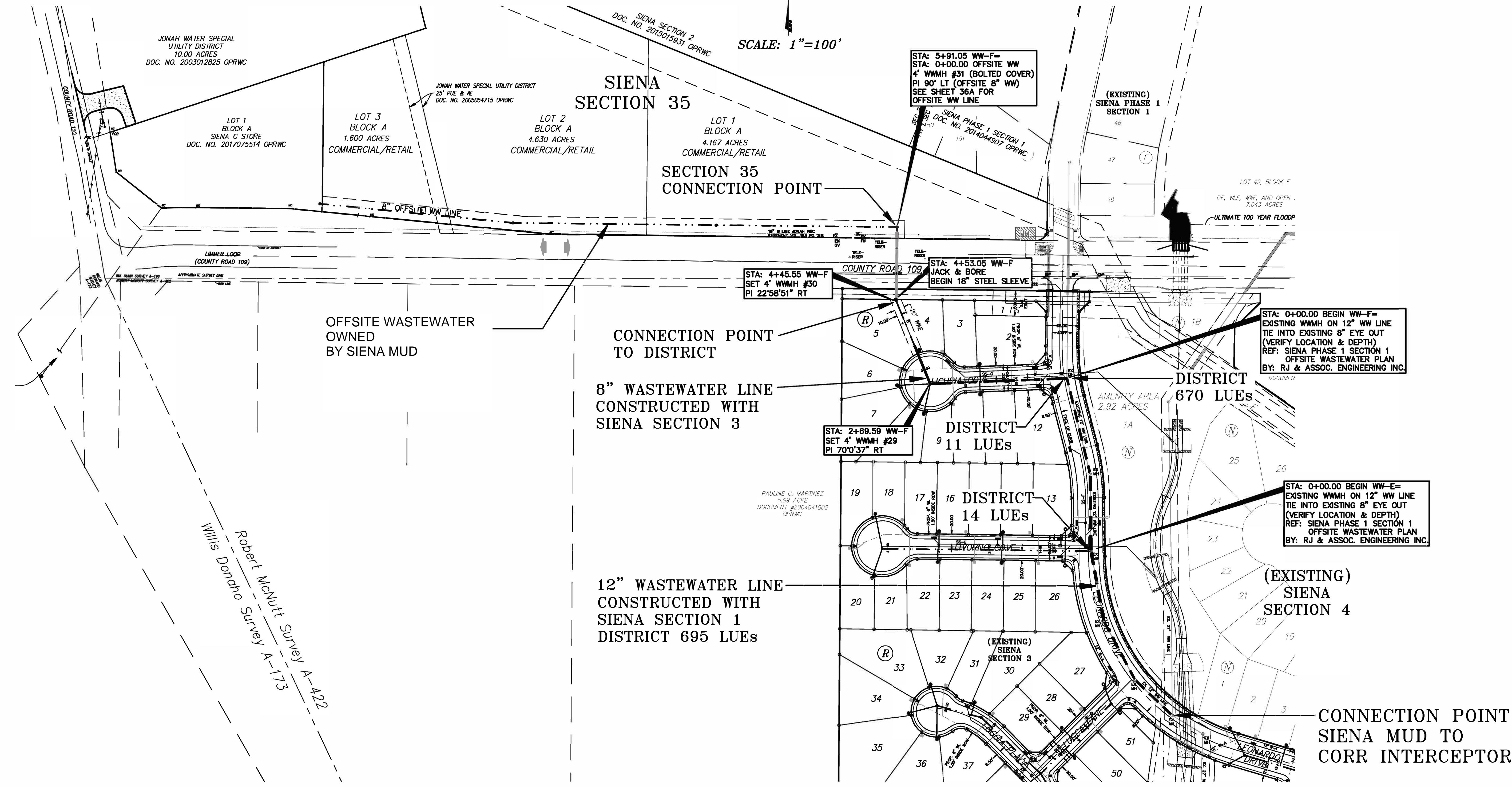

NO.	DATE	DESCRIPTION	BY

RANDALL JONES & ASSOCIATES ENGINEERING INC.
#9784
2900 JAZZ STREET
ROUND ROCK, TX 78664
(512) 836-4793

PROJECT: **Siena Section 35, Lot 1 ESD SITE**
SHEET: **WASTEWATER PASS THROUGH EXHIBIT**

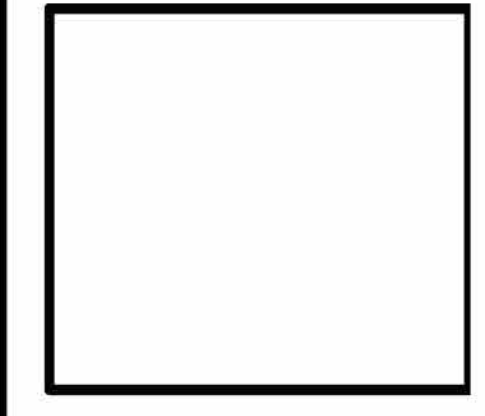

DATE: APRIL 2020
DRAWN: EPAN
CHECKED:
FILE: 1389
SCALE: AS SHOWN

SHEET
X01

from: R:\LAND 2451-2500\2488 SIENA 3\DWG\2488-34_36 WW PLAN.dwg
 R:\LAND\1351-1400\1389 Siena MUD #1.dwg
 R:\LAND\1351-1400\1389 Siena MUD #1.dwg
 R:\LAND\1351-1400\1389 Siena Section 35 Lot 1 ESD Site EXHIBIT.dwg
 Apr 09, 2020

Willis Donho Survey A-173
Robert McNitt Survey A-422

EXHIBIT “C”
PASS THROUGH AGREEMENT WITH SIENA MUD

[See following page.]

**AGREEMENT FOR PASS-THROUGH WASTEWATER SERVICE
[LOT 3, BLOCK A, SIENA SECTION 35]**

THIS AGREEMENT FOR PASS-THROUGH WASTEWATER SERVICE [LOT 3, BLOCK A, SIENA SECTION 35] (this "Agreement") is entered into effective as of the Effective Date (defined below), by and among **SIENA MUNICIPAL UTILITY DISTRICT NO. 1**, a political subdivision of the State of Texas operating under Chapters 49 and 54 of the Texas Water Code ("District No. 1"), **SIENA MUNICIPAL UTILITY DISTRICT NO. 2**, a political subdivision of the State of Texas operating under Chapters 49 and 54 of the Texas Water Code ("District No. 2" and, collectively with District No. 1, the "Districts"), **ELMURR, LLC**, a Texas limited liability company ("ELMURR"), and the **CITY OF ROUND ROCK, TEXAS**, a home rule municipality located in Williamson County, Texas (the "City"). District No. 1, District No. 2, ELMURR, and the City are sometimes referred to individually in this Agreement as a "Party" and collectively as the "Parties".

RECITALS:

A. District No. 1 purchases and receives wholesale wastewater service from the City pursuant to the Wholesale Wastewater Agreement dated June 27, 2013 between District No. 1 and the City (the "District No. 1 Wholesale Agreement"); and District No. 2 purchases and receives wholesale wastewater service from the City pursuant to the Wholesale Wastewater Agreement dated June 27, 2013 between District No. 2 and the City (the "District No. 2 Wholesale Agreement" and, collectively with the District No. 1 Wholesale Agreement, the "Wholesale Agreements").

B. ELMURR is planning to develop Lot 3, Block A, SIENA SECTION 35, a subdivision in Williamson County, Texas, according to the map or plat thereof recorded under Document No. 2020046670 (the "Property"), with an $\pm 9,307$ square foot building, comprised of a "General Retail" uses, as defined in the City's Code of Ordinances. The City has represented to ELMURR that 6 living unit equivalents ("LUEs") of wastewater capacity in the City's wastewater system are available for use by ELMURR to serve the Property. However, because the City does not have existing wastewater lines in the area to which the Property could readily connect, ELMURR has requested to use the Districts' wastewater systems on a pass-through basis in order to obtain retail wastewater service from the City to the Property.

C. The Parties desire to enter into this Agreement to set forth the terms and conditions on which the City and ELMURR may utilize the Districts' wastewater systems to provide wastewater service to the Property on a pass-through basis.

AGREEMENT

For and in consideration of the mutual promises, covenants, obligations, and benefits of this Agreement, the Parties contract and agree as follows:

Section 1. Recitals. The above and foregoing recitals are incorporated herein by reference.

Section 2. Pass-Through Wastewater Service.

A. Authorization of Pass-Through Service. Subject to the terms and conditions of this Agreement, the City may connect a wastewater line owned by

ELMURR (the "ELMURR Wastewater Line") to the Districts' wastewater lines (the "District Wastewater Lines") and wastewater collection systems at the point of connection identified as the "Lot 3 Connection to Existing system" on **Exhibit "A"** attached hereto (the "District Wastewater Point of Connection") to allow the City to provide up to 6 LUEs of retail wastewater service to the Property using the Districts' wastewater systems on a pass-through basis. The Districts have reviewed their current capacity and have determined that they have the wastewater capacity to allow 6 LUEs of wastewater to pass from the Property through their wastewater lines to the City's wastewater system in accordance with this Agreement.

B. Limitations and other Conditions of Service.

1. Notwithstanding anything else in this Agreement to the contrary, in no event will the City or ELMURR, without the prior written consent of the Districts, deliver through the Districts' wastewater collection system more than 6 LUEs of wastewater from the Property measured at the District Wastewater Point of Connection.

2. District No. 1 has and will continue to have its guaranteed reservation and commitment of 2,556 LUEs of wastewater capacity from the City under the District No. 1 Wholesale Agreement; and District No. 2 has and will continue to have its guaranteed reservation and commitment of 2,556 LUEs of wastewater capacity from the City under the District No. 2 Wholesale Agreement. None of the LUEs of capacity guaranteed and reserved to the Districts under the Wholesale Agreements will be utilized to serve the Property under this Agreement. Instead, the City is committing 6 LUEs of wastewater capacity directly to the Property and will simply be using the Districts' wastewater systems to provide retail wastewater service to the Property on a pass-through basis.

3. To the extent that ELMURR desires to make improvements to the Property that would impact wastewater generation, ELMURR will submit all plans and specifications for such improvements to the Districts prior to construction of such improvements so that the Districts may confirm that wastewater generated from such improvements will not exceed the maximum limits set forth in this Agreement. Each submission will include an engineer's calculation of LUEs of wastewater service proposed and the peak wet weather wastewater flows that will be generated by the improvements, and such calculation will be subject to confirmation and approval by the Districts. Further, within ten days after approval by the applicable governmental authority, ELMURR will provide the Districts with copies of all approved site plans, and amendments thereto. ELMURR will be solely responsible for the cost of any infrastructure improvements to ELMURR's or the City's wastewater systems that are necessary to enable the City to provide retail wastewater service to the Property, including the ELMURR Wastewater Line from the Property to the District Wastewater Point of Connection (the "ELMURR Wastewater Facilities") and ELMURR will, at its sole cost and expense, operate and maintain the ELMURR Wastewater Facilities in compliance with all applicable rules and regulations; provided, however, that the ELMURR Wastewater Facilities may be dedicated to the City, in which case the City will accept the ELMURR Wastewater Facilities for operation and maintenance.

4. **THE DISTRICTS WILL HAVE NO LIABILITY OF ANY KIND OR NATURE WITH RESPECT TO THE ELMURR WASTEWATER FACILITIES, AND DEVELOPER WILL INDEMNIFY, DEFEND, AND HOLD THE DISTRICTS AND ITS DIRECTORS, OFFICERS, EMPLOYEES, CONSULTANTS, AGENTS, AND REPRESENTATIVES HARMLESS FROM AND AGAINST ANY AND ALL COSTS, DAMAGES, LIABILITIES (INCLUDING REASONABLE ATTORNEYS' FEES AND COSTS OF LITIGATION), SUITS, ACTIONS, LEGAL, OR ADMINISTRATIVE PROCEEDINGS, DEMANDS, FINES, PUNITIVE DAMAGES, LOSSES, COSTS, OR CLAIMS OF ANY KIND OR NATURE (COLLECTIVELY, "COSTS") THAT ARISE BECAUSE OF OR IN CONNECTION WITH THE USE, OPERATION, OR MAINTENANCE OF THE ELMURR WASTEWATER FACILITIES. SUCH OBLIGATION APPLIES WHETHER ACTUAL OR ALLEGED NEGLIGENT ACTS OR OMISSIONS OF THE DISTRICTS CAUSED THE LOSS IN WHOLE OR IN PART; PROVIDED HOWEVER, IN THE EVENT OF ANY JOINT OR CONCURRENT LIABILITY BETWEEN THE DISTRICTS AND DEVELOPER, DEVELOPER'S OBLIGATIONS HEREIN WILL BE REDUCED BY THE PERCENTAGE OF NEGLIGENCE OR FAULT APPORTIONED TO THE DISTRICTS.**

5. ELMURR and the City will be responsible for ensuring that all discharges of industrial waste from the Property comply with federal, state, and municipal requirements regarding pretreatment and monitoring of industrial waste and other prohibited waste. Any compliance or enforcement efforts or pretreatment requirements will be established and monitored by the City in accordance with the City's ordinances; however, the Districts will be entitled to inspect the facilities constructed to serve the Property and the connections at the District Wastewater Point of Connection and to test the wastewater received at the District Wastewater Point of Connection. If any test reflects that any wastewater other than domestic wastewater is being received at the District Wastewater Point of Connection, pretreatment of such wastewater will be required, in accordance with the City's ordinances, at the expense of the discharging party. The Districts will not have any obligations regarding the required pretreatment of such wastewater. The City will not impose any fee, charge, or fine upon the Districts for any violation of any ordinance, rule, regulation, or agreement caused by wastewater received at the District Wastewater Point of Connection, nor will the City impose upon the Districts any surcharge that is caused by wastewater received at the District Wastewater Point of Connection.

6. The 6 LUEs of wastewater service authorized under this Agreement may only be used to provide wastewater service to ELMURR for the Property. Except as expressly authorized by this Agreement for pass-through wastewater service to the Property, neither ELMURR nor the City may connect, or allow any other person or entity to connect, directly or indirectly, any other facilities, persons, or property to the Districts' water or wastewater utility systems without the prior written consent of the Districts. If ELMURR or the City does so, the Districts may immediately terminate this Agreement and/or require ELMURR or the City, as applicable, to immediately terminate service to the facilities, persons, or property that have been connected in violation of this

Exhibit "C"

Agreement. The Districts reserve the right to deny for any reason any request by ELMURR or the City to increase the level of service under this Agreement or to serve any other facilities, persons, or property.

C. Capacity Charge. For the 6 LUEs of pass-through wastewater service capacity made available under this Agreement to the Property, ELMURR will pay a non-refundable capacity charge of **\$3,485.25** to District No. 1 and **\$646.28** to District No. 2 (collectively, the "Capacity Charges"). The Capacity Charges must be paid on or before the Effective Date.

D. Operation & Maintenance Payment. The Districts will each invoice ELMURR for a prorata portion of the costs of the operation and maintenance of the District Wastewater Lines used to provide pass-through wastewater service to the Property under this Agreement (the "Operation & Maintenance Payments"). The Operation & Maintenance Payments will be allocated based on the ratio of the number of LUEs of pass-through wastewater service capacity made available under this Agreement to the Property (provided that such number will not include any LUEs for which the Capacity Charges have been paid until such LUEs are actually being utilized) to the total number of wastewater LUE capacity in the District Wastewater Lines, as set forth on Exhibit "B" attached hereto (the "Prorata Allocation"). The Operation & Maintenance Payments will be paid by ELMURR within 30 days after receipt of the invoice. The Operation & Maintenance Payments will be in addition to any other payments required by this Agreement. Interest charges for any overdue Operation & Maintenance Payments will be paid by ELMURR in accordance with Texas Government Code Section 2251.025.

E. Debt Service Payment. On or before October 31st of each year during the term of this Agreement through and including 2043, ELMURR will pay an annual fee of **\$23** per LUE to District No. 1 and an annual fee of **\$4** per LUE to District No. 2 for the debt service for the District Wastewater Lines used to provide pass-through wastewater service to the Property under this Agreement (collectively, the "Debt Service Payments"), except that any LUEs will not be factored into the Debt Service Payments until such LUEs are actually being utilized. The Debt Service Payments are ELMURR's Prorata Allocation of the debt service owed for the District Wastewater Lines. The amount of the Debt Service Payments may be adjusted by the Districts annually to reflect the actual debt service for the District Wastewater Lines, if such debt service changes; provided, however, the Districts shall provide written notice to ELMURR of any adjustment at least thirty days prior to the effective date of such adjustment. The Debt Service Payments will be in addition to any other payments required by this Agreement. Interest charges for any overdue Debt Service Payments will be paid by ELMURR in accordance with Texas Government Code Section 2251.025.

F. Payment for Retail Service. The City will bill wastewater customers within the Property directly for retail wastewater services furnished to such customers.

Section 3. Default. In the event of default by a Party, each nondefaulting Party may give to the defaulting Party written notice of such default specifying the failure or default in question. If the defaulting Party fails to fully cure the default specified in such notice within thirty days after receipt of such notice, each nondefaulting Party will have the right to terminate this Agreement as of the date of the event of the default and/or pursue all other legal or equitable remedies. Each nondefaulting Party may employ attorneys to pursue its legal rights and, if it prevails before any court or agency of competent jurisdiction, the defaulting Party will

be obligated to pay all expenses incurred by the nondefaulting Party, including reasonable attorneys' fees. In addition to all other remedies available to the Districts, if, for any reason, ELMURR or the City violates any provision of this Agreement, the Districts will, after the notice and opportunity to cure period described above, have the right to disconnect the Property from the Districts' systems and to terminate this Agreement if, in which event, ELMURR will be solely responsible for all actual costs and standard District fees related to disconnection from the Districts' systems.

Section 4. Severability. The provisions of this Agreement are severable, and if any provision or part of this Agreement or the application thereof to any person or circumstance is ever be held by any court of competent jurisdiction to be invalid or unconstitutional for any reason, the remainder of this Agreement and the application of such provision or part of this Agreement to other persons or circumstances will not be affected thereby.

Section 5. Modification. This Agreement will be subject to change or modification only with the mutual written consent of all Parties.

Section 6. Assignability. This Agreement may not be assigned by ELMURR or the City, in whole or in part, without the prior written consent of the Districts. This Agreement will be recorded in the Official Public Records of Williamson County, Texas, will run with the land comprising the Property, and will be binding upon and inure to the benefit of the Parties, their respective successors and permitted assigns, and all future owners or occupants of any portion of the Property.

Section 7. Applicable Law. This Agreement will be governed by, and construed in accordance with the laws of the State of Texas. All of the obligations contained in this Agreement are performable in Williamson County, Texas.

Section 8. Parties at Interest. This Agreement will be for the sole and exclusive benefit of the Parties hereto and will never be construed to confer any benefit to any third party.

Section 9. Waiver. Each Party may specifically, but only in writing, waive any breach of this Agreement by another Party, but no such waiver will be deemed to constitute a waiver of similar or other breaches by such other Party.

Section 10. Notices. All notices to the Districts will be in writing and mailed by Certified Mail, Return Receipt Requested, addressed to:

Siena Municipal Utility District No. 1
c/o Armbrust & Brown, PLLC
Attn: Kevin M. Flahive
100 Congress Avenue, Suite 1300
Austin, Texas 78701

Siena Municipal Utility District No. 2
c/o Armbrust & Brown, PLLC
Attn: Kevin M. Flahive
100 Congress Avenue, Suite 1300
Austin, Texas 78701

with copies to:

Armbrust & Brown, PLLC
Attn: Kevin M. Flahive
100 Congress Avenue, Suite 1300
Austin, Texas 78701

All notices to ELMURR will be in writing and mailed by Certified Mail, Return Receipt Requested, addressed to:

ELMURR, LLC
Attn: Nabil El Murr
3800 Hidden Estates Drive
Austin, Texas 78727

All notices to the City will be in writing and mailed by Certified Mail, Return Receipt Requested, addressed to:

City of Round Rock
Attn: City Manager
221 East Main Street
Round Rock, Texas 78664

with a copy to:

Sheets & Crossfield, P.L.L.C.
Attn: Stephanie L. Sandre
309 East Main Street
Round Rock, TX 78664

Any Party may change its address by giving written notice of such change to the other Parties.

Section 11. Term. This Agreement will be in force and effect for the term of the Wholesale Agreements.

Section 12. Effective Date. The effective date of this Agreement (the "*Effective Date*") will be the date that the latter of the Districts executes this Agreement after receipt of fully executed original counterparts from ELMURR and the City.

Section 13. Multiple Originals. This Agreement may be executed in a number of counterparts, each of which will for all purposes, be deemed to be an original, and all such counterparts will together constitute and be one and the same instrument.

Section 14. Entire Agreement. This Agreement, including Exhibits, constitutes the entire agreement of the Parties and supersedes all prior agreements and understandings related to the subject matter hereof.

Section 15. Authority. Each Party represents and warrants that it has the full right, power, and authority to execute this Agreement and all related documents. Each person executing this instrument on behalf of a Party represents that he or she is an authorized representative of and has the authority to sign this document on behalf the respective Party.

Section 16. IN WITNESS WHEREOF, the Parties have caused this Agreement to be executed effective as of the Effective Date.

DISTRICT NO. 1:

SIENA MUNICIPAL UTILITY DISTRICT NO. 1

By: 
Douglas Kuenstler, President
Board of Directors

Date: October 18, 2023

THE STATE OF TEXAS §
 §
COUNTY OF TRAVIS §

This instrument was acknowledged before me on the 18th day of October, 2023, by Douglas Kuenstler, President of the Board of Directors of Siena Municipal Utility District No. 1, on behalf of said District.

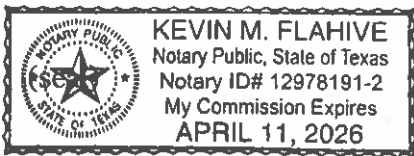



Notary Public Signature

DISTRICT NO. 2:

SIENA MUNICIPAL UTILITY DISTRICT NO. 2

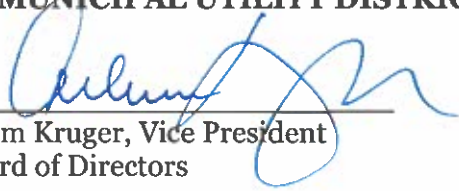
By: 
Adam Kruger, Vice President
Board of Directors

Date: October 18, 2023

THE STATE OF TEXAS §
 §
COUNTY OF TRAVIS §

This instrument was acknowledged before me on the 18th day of October, 2023, by Adam Kruger, Vice President of the Board of Directors of Siena Municipal Utility District No. 2, on behalf of said District.

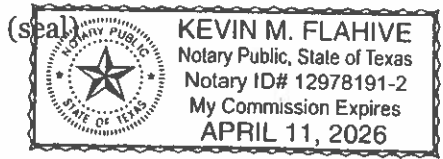

Notary Public Signature

ELMURR:

ELMURR, LLC,
a Texas limited liability company

By: Nabil Elmurr
Name: NABIL ELMURR
Title: MANAGING MEMBER

Date: 11/06/2023

THE STATE OF TEXAS §
 §
COUNTY OF Williamson §

This instrument was acknowledged before me on the 6th day of November, 2023,
by NABIL ELMURR of ELMURR, LLC, a Texas limited liability
company, on behalf of said limited liability company.

(seal)

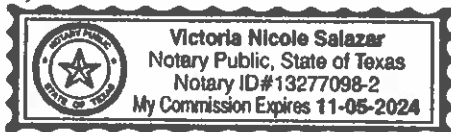

Notary without Bond

[Handwritten Signature]

Notary Public Signature

CITY:

CITY OF ROUND ROCK, TEXAS

By: _____
Craig Morgan, Mayor

Date: _____

THE STATE OF TEXAS §
 §
COUNTY OF _____ §

This instrument was acknowledged before me on the ____ day of _____, 2023,
by Craig Morgan, Mayor of the City of Round Rock, Texas, on behalf of said City.

(seal)

Notary Public Signature

EXHIBIT "A"
DISTRICT WASTEWATER POINT OF CONNECTION

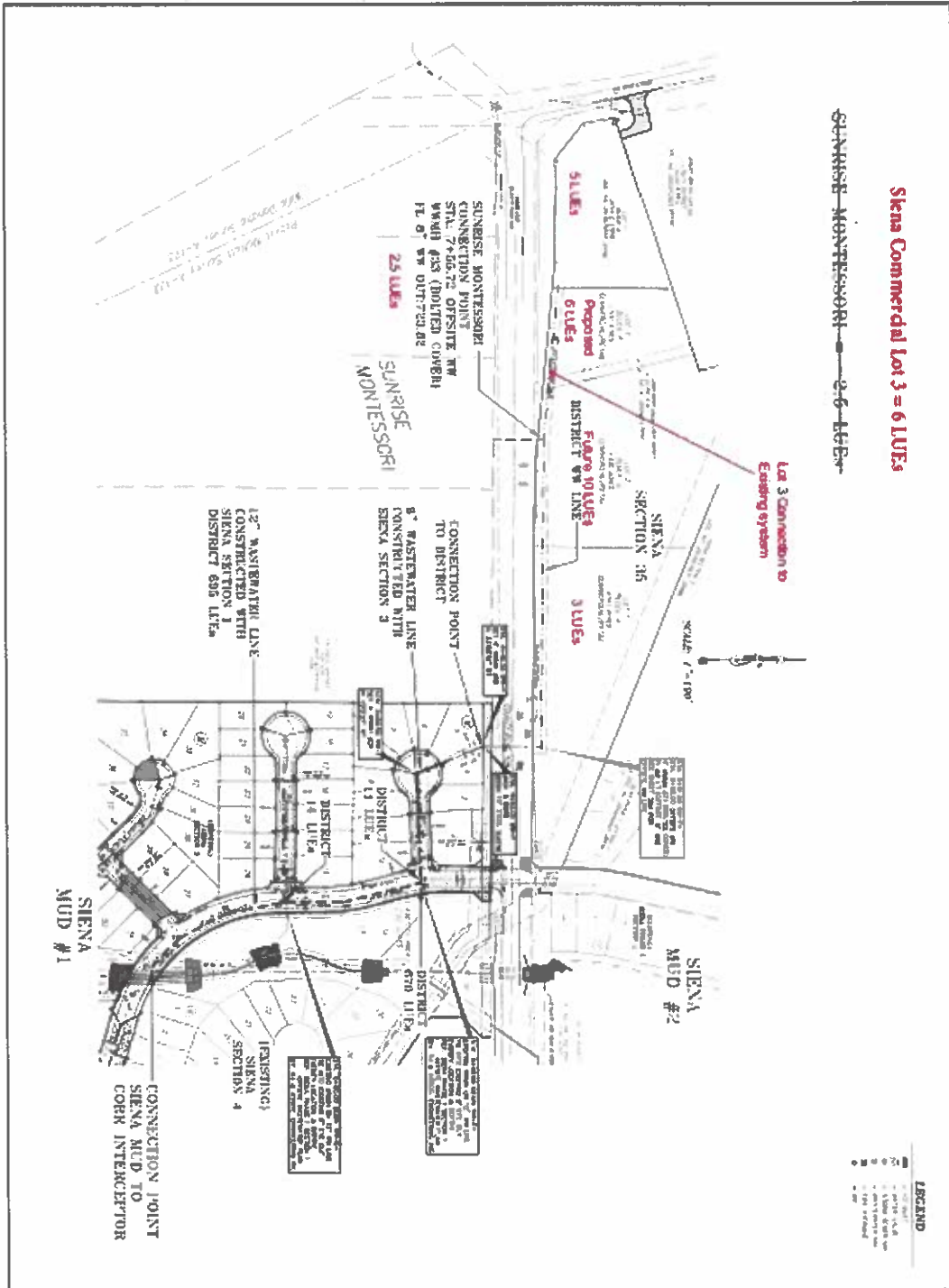

EXHIBIT "B"

PRORATA ALLOCATION

Siena MUD 1 WW Allocation for Siena Commercial Along CR 109

Segment	MH ID	Pipe Size (in)	Slope (%)	Unit	Cost	Siena Lues	Total Costs
Sect 1 Contract							
		12	0.5		Line A	695	
	Std MH			4	4,000.00		16000
	Drop MH			1	4,900.00		4900
	12 " 10-12' deep			616	37.00		22792
	12 " 12-14' deep			51	62.00		3162
	12 " 14-16' deep			50	68.00		3400
	Connect to Ex			1	1,800.00		1800
	Trench Safety			717	1		717
	Adjust MH			5	100		500
							53,271.00
Sect 3 Contract							
		8	0.5		Line F	11	
	Std MH			1	3,500.00		3500
	8 " 0-8' deep			150	32.00		4800
	8 " 8-10' deep			100	34.00		3400
	8 " 10-12' deep			100	39.00		3900
	Connect to Ex			1	1,000.00		1000
	Trench Safety			350	0.5		175
	Adjust MH			1	100		100
							16,875.00
Total Costs							\$70,146.00
Pro-Rated Costs		Sect 3		Sect 1		Total Pro-Rated Costs	
Lot 3	6 LUES	8" Line		12" Line			
		\$2,700.00		\$443.00			\$3,143.00
Total							\$3,143.00

Exhibit "C"

Developer Interest Calculations			
Lot 3			
Series 2018 Bonds	3.77%	Costs	Interest
Subtotal Section 1 Costs		\$443.00	
Completed 10/14			
Assume 10/23 close	108 months		\$150.12
Series 2019 Bonds	3.31%	Costs	Interest
Subtotal Section 3 Costs		\$2,700.00	
Completed 8/18			
Assume 10/23 close	62 months		\$461.25
Total Developer Interest			\$611.37
Total Costs			
Construction			
Pro-rated share through Section 1			\$443.00
Pro-rated share through Section 3			\$2,700.00
Engineering and Testing @ 12% construction costs			
Section 1			\$53.16
Section 3			\$324.00
Developer Interest			
Section 1			\$150.12
Section 3			\$461.25
Total Costs Per Section			
Section 1			\$646.28
Section 3			\$3,485.25
Total Cost for Pass- Through Service for Lot 3			\$4,131.53

Prepared by :
 Jones - Heroy & Associates, Inc.
 TBPE Firm #F-006320

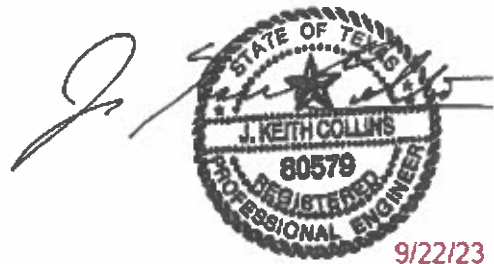

EXHIBIT “D”

Zoning and Development Code, Chapter 4, Article VI, Sec. 4-80

Sec. 4-80. - Furnishing of water, reuse water, and sewer services outside city limits.

- (a) *Conditions under which city services will be provided.* The city shall furnish water, sewer and/or reuse water services to residential and commercial users located outside the city limits only upon the following conditions:
- (1) *Adequate capacity exists.* There is adequate capacity of city services available for the purpose of servicing residential and commercial users outside the city without impairing services within the city. Whether such adequate capacity exists shall be determined solely by the city council, and the determination of the city council shall be final.
 - (2) *Owners outside city limits to bear costs of lines and furnish easements.* The construction costs of water, sewer and/or reuse water lines and appurtenances which serve residential and commercial users outside the city limits shall be paid for by the owner, developer, or political entity requesting the service. Such owner, developer, or political entity shall also furnish suitable construction and permanent easements and rights-of-way for utility lines.
 - (3) *Construction to conform to city standards.* All design and construction shall be in accordance with city standards and specifications.
 - (4) *New subdivisions to comply with subdivision regulations.* New subdivisions recorded after the date of passage of this section desiring city water, sewer and/or water reuse services shall comply with the subdivision regulations of the City of Round Rock, Texas, in effect at the time such new subdivision is approved. Existing subdivisions whose plats were recorded with the County Clerk of Williamson County, Texas, at the time of the passage of the original Ord. No. 269 (January 8, 1976) can be furnished with water and sewer services without the necessity of having sanitary sewer collection and treatment facilities.
 - (5) *City to have right of review.* The city shall have the right to review and approve all plats and plans and inspect and approve all water, sewer and/or reuse water construction within subdivisions where water, sewer, and/or reuse water service is to be provided.
 - (6) *Water and sewer facility requirements.* Except as provided in subsection (4) of this section, all residential and commercial users shall have sanitary sewer collection and treatment facilities. Water will not be provided to residential and commercial users who utilize septic tanks save and except water can be provided to subdivisions whose plats were recorded with the County Clerk of Williamson County, Texas, at the time original Ord. No. 269 was adopted (January 8, 1976).
 - (7) *Water, sewer, and/or reuse water lines to meet ultimate requirements of city.* Where water, sewer, and/or reuse water lines and appurtenances are extended outside the city limits, the lines shall be sized to serve the ultimate requirements of the city.
 - (8) *Extended lines to be designed and inspected by city's engineer.* All water, sewer, and/or reuse water lines and appurtenances extending from existing city facilities to any tract of land outside the city limits requesting water, sewer, and/or reuse water service shall be designed and inspected by the city's engineer. The owner, developer, or political entity requesting the service shall pay for these services in keeping with the current contract between the city and the engineer employed by the city.
 - (9) *City may reimburse owner for oversized lines.* Where the size of the water, sewer, and/or reuse water lines required to meet the ultimate requirements for the city is larger than eight inches and the total capacity is not required to serve the tract of land to be developed, the city may enter into a contract with the owner, developer, or entity constructing the lines for reimbursement for the excess capacity as other users request and are granted service. The developer or entity requesting service from an existing line shall pay a tap fee on a pro rata basis, as hereinafter set

forth. The reimbursement to the owner, developer, or entity who paid for the line construction shall be made only from those tap fees paid to the city by users of the facility paid for by the said owner, developer, or entity.

- (10) *Pro rata basis for tap fee.* The pro rata basis for the tap fee shall be computed based upon the required demand for use and the fire protection as specified by the engineering criteria approved by the city's engineer. The basis for cost shall be the actual total cost of the facility plus five percent (5%) interest. The total cost shall include, but shall not be limited to, construction costs, engineering costs, and inspection costs.
 - (11) *Wholesale bulk rate sales of water.* Facilities constructed and paid for by another public entity or facilities which will later be acquired by a public entity may be owned, operated, and maintained by that entity. Such facilities shall purchase water from the city at a negotiated wholesale bulk rate. The city shall own, operate, and maintain all other facilities.
- (b) *Rates.* The rates paid by residential and commercial users located outside the city limits for the use of the water, sewer, and/or reuse water facilities of the city shall be in accordance with sections 44-32, 44-33, and 44-34 of the Code of Ordinances.